

STAINLESS STEEL **BRIGHT BARS**



BAR | WIRES | WELDING WIRES



bitly

COMPANY PROFILE

Introduction

As a distinguished Indian company with a legacy of 5 decades in the Stainless Steel Industry, Venus has established itself as a leading manufacturer and exporter of premium stainless steel wires and bars.

Our global footprint spans over 50+ countries, reflecting our steadfast commitment to delivering superior products.

Delve into our meticulously curated range, underpinned by a legacy of redefined industry benchmarks through unwavering dedication to quality and innovation.

Mission

With our forward thinking and passion for service and innovation, we strive to help our customer optimize their productivity and build the most advanced products for the future world.

Vision

To be a global leader in stainless & special steel long products known for its quality, continuous innovation, and impeccable service level.



WHY CHOOSE VENUS WIRES?

Uncompromising Quality

Quality is the essence of our culture; it defines everything we do.

Seamless Service

We provide global customers with an exceptional experience, akin to having a next-door vendor.

Sustainable Solutions

Our products are engineered with the most sophisticated and sustainable technologies, contributing to a better world.

People-Powered

Our dedicated team forms the backbone of our success, and we pride ourselves on the industry's lowest attrition rate.

Specialized Expertise

With over 5 decades of dedicated focus on manufacturing stainless and special steel wires and bars, we are global leaders in our domain.

Continuous Innovation

We invest in research and development, cutting-edge machinery, and systems, and nurturing our skilled workforce to progress continually.

Customer-Centric Approach

At the heart of our operations lies a passion for helping our customers achieve their goals and become industry leaders.



APPROVALS

System Certifications

ISO 9001:2015 | ISO 14001:2014 | ISO 45001:2018 | AD 2000 Merkblatt WO
PED AD 2000 TRP 1000 | TS 16949 | AS9100 | NORSOK M - 650 | CPD | NABL



SUSTAINABILITY

At Venus Wires Industries, sustainability is an integral part of our core values and business philosophy. As a leading player in the Stainless Steel Industry, we recognize our responsibility to prioritize environmental, social, and economic considerations in all aspects of our operations. With a commitment to creating a greener future, we have embraced sustainable practices that not only drive our success but also contribute positively to the communities we serve and the planet we call home.



Safety and sustainable living for our employees



Carbon management



Green energy



Circular economy



Energy monitoring and efficiency



Water and environment conservation



Social corporate responsibility



PRODUCT PROFILE

CC BILLETS AND INGOT

- 160 mm (6.30")
- 200 mm (8")
- 250 mm (10")

ROLLED BILLETS (ROUND CORNER SQUARE)

- 75 - 160 mm (3" - 6")

HOT ROLLED BARS

- 21 - 230 mm (0.826" - 9.05")
- 22 - 58 mm (0.866" - 2.28")
- 22 - 58 mm (0.866" - 2.28")

WIRE ROD & PEELED WIRE ROD

- 5 mm - 34 mm (0.187" - 1.34")

COLD DRAWN / GROUND BARS

- 1 - 32 mm (0.039" - 1.25")
- 3 - 90 mm (0.11" - 3.54")
- 3 - 90 mm (0.11" - 3.54")
Magnetic Annealed Bars
- 4.5 - 51 mm (0.117" - 2")

DRAWN WIRE

- 0.10 - 28 mm (0.009" - 1.10")
Coils / Spools basket. Reels

PEELED POLISHED / GROUND BARS

- 27mm-350mm (1.00" - 13.77")

STRAIN HARDENED ROUND (HIGH TENSILE)

- 10mm-100mm (0.25" - 3.5")

FORGED ROUND BARS

205mm- 500mm
(8.00" - 20.00")

PRODUCT PROFILE- FLATS AND ANGLES

ANGLES

SIZE

19x19mm -
60mmx60mm
(0.75"x0.75" - 2.25x2.25")

65x65mm - 100x100mm
(2.5"x2.5" - 4"x4")

THICKNESS

3-6mm (0.118"-0.25")
5-10mm (0.2"-0.375")

FLAT BARS

SIZE

Width - 20-50mm
(0.750" - 2")

THICKNESS

3-32mm (0.118" - 1.25")

GFM FORGED FLAT BARS (NOT MACHINED OR MILLED)

SIZE

2" - 6"

THICKNESS

3.15" - 14"

PRESS FORGED FLAT BARS (CONDITIONED, PLANING OR MILLED)

SIZE

2" - 6"

THICKNESS

3.15" - 14"

ROUND BARS

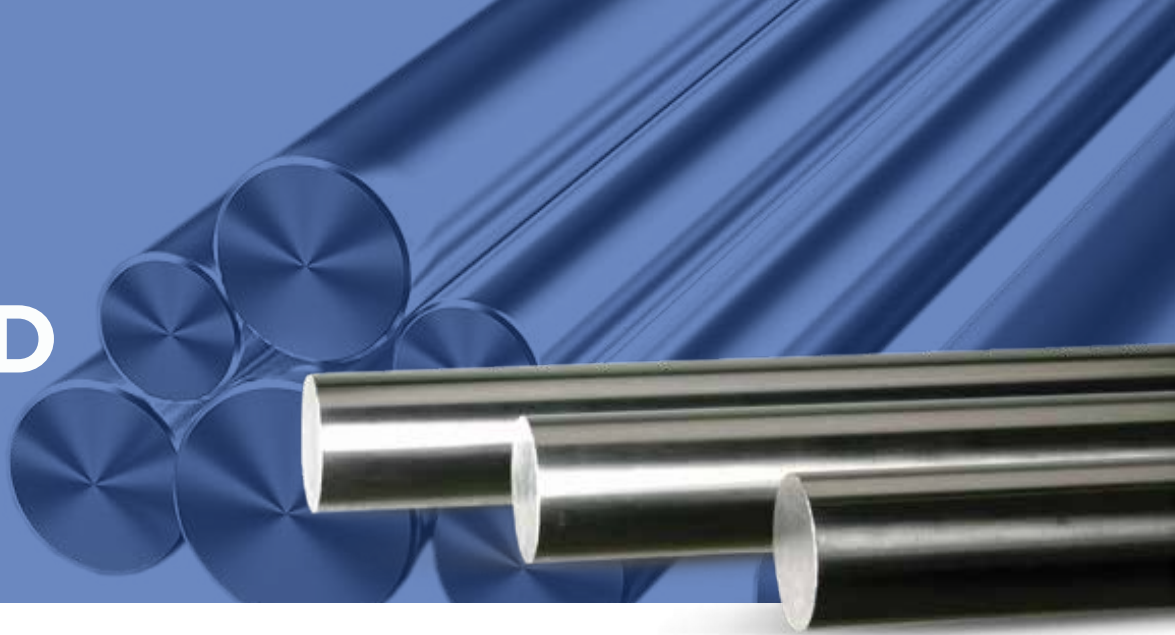

SIZE RANGE:

Diameter

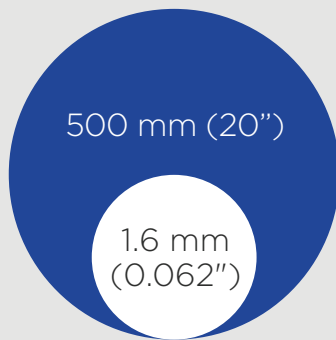

DIAMETER TOLERANCE:

ASTM A484

ISO 286 - e6, fS, f6, f7, f8, gs, g6, g7, g8, h6, h7, h8, h9, h10, h11, h12, j6, k10, k11, k12, k13
Custom tolerance

LENGTH:

Upto 10.36 meters (34' max.)
Bright, Matte & Semi Bright

HEAT TREATMENTS

- Annealed
- Hardened & Tempered
- Aged
- Magnetic Annealed
- Heat Treated

SUPPLY CONDITION

- Cold drawn
- Cold drawn, center less ground & polished
- Strain hardened
- Peeled & polished
- Peeled, center less ground & polished
- Forged round bars

Surface Finish

- Maximum 16 RMS

Quenching Media

- Air
- Water
- Oil

Straightness

- As per ASTM A484
- 0.5 mm per meter

Chamfering

- 30°C, 45°C and 60°C
- 0.5 mm to 12 mm depending on the angle

Marking & Identification

- Stamping one end or both end for size 1" and above.
- Color code
- Sticker as alternative to stamping



PROFILE BARS

SIZE RANGE:

FOR HEX & SQUARE: 5 mm (3/16") to 90 mm (3.54")

FOR FLAT:

Width 20-50 mm (0.75"-2") thickness 3-32 mm (0.118"-1.25")

Width 65-100 mm (2.5"-4") thickness 6-32 mm (0.24"-1.25")

GFM forged Flat Bars (Not machined or milled) - Width 50-150 mm (2"-6") thickness 80-350 mm (3.15"-14")

Press forged Flat Bars (Condition, Planed or milled) - Width 50-150 mm (2"-6")

thickness 80-350 mm (3.15"-14")

LENGTH:

Upto 6 meters max. (20" max.)

HEAT TREATMENTS:

300/400 Series Annealed

SUPPLY CONDITION:

Cold Drawn & Polished

DIAMETER TOLERANCE:

ASTM A 484/ISO h11/150 k12





VSO BARS

(Venus Shaft Quality)

PNEUMATIC CYLINDER | PUMP SHAFT | PRECISION GROUND | MIRROR POLISHED

Our bars are crafted with precision from high quality stainless steel, offering exceptional durability and corrosion resistance. Rigorous quality checks ensure they meet industry standards, making them ideal for demanding pump manufacturing applications. Within the stainless and nickel sectors, Pump Shaft Quality (PSQ) refers to shafting that has undergone turning, grinding, and polishing processes for use in rotating industries. The precision in diametrical tolerance achieved through grinding reduces wear and ensures a consistently high-quality product with controlled properties.

SIZE RANGE:

Diameter

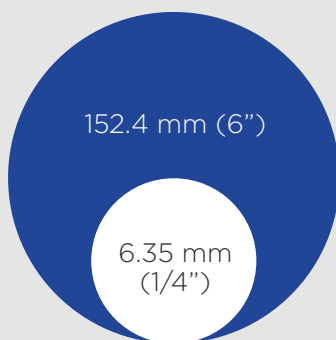

DIAMETER TOLERANCE:

Custom tolerance

SALIENT FEATURES:

- Precision straightened bars
- Mirror finish
- Highly controlled heat treatment with SCADA control
- Highest supply size - 152.4 mm (6")
- Precision tolerance
- Lowest supply size - 6.35 mm (1/4")
- Round bars
- Close length tolerance
- Ultrasonic/magnetic particle
- Eddy current testing by n-circling, rotating probe
- Unique packaging
- Certified to all major international specs



"FITMACH"

FREE MACHINING GRADES

Traditional 'free machining' stainless steel grades rely on sulfur (S) additions, forming evenly distributed manganese-rich sulfides or selenides. These act as chip breakers during machining, allowing for increased machining speeds and prolonged cutting tool life. Additionally, the 'non-metallic' inclusions can serve as a solid lubricant at the tool/workpiece interface, potentially enhancing surface finish.

FEATURES

- Offered in round, square and hexagon bars
- Close size tolerance - f6, e8, h7, h8, h9
- Straightness below 0.5mm/mtrs
- $Ra < 0.5 \mu m$
- Eddy current and UT tested
- Free from any defects
- Can be produce from peeled wire rod on request.

VALUE ADDITION

- Less down time
- Less material stuck up and vibration in collate
- Improved tool life
- Great accuracy of finished parts
- Nearly zero crack



TRU:TUF

(The Tough Bar)

SIZE RANGE:

Diameter

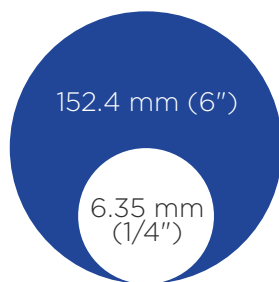

AREA OF APPLICATIONS

- Oil field applications
- Aircraft fittings
- Pump shafts
- Reactor components
- Aircraft engine parts
- Mill equipment's and many more...

HEAT TREATMENTS

- Solution annealed
- H 900/H925/H1025/H1075/ H1100/H1150/H1150 D/H1150 M
- Custom aged conditions
- Tested to customized conditions
- High Impact Strength
- In-compliance with NACE, API, SAE, AMS, ASTM, MIL, EN10088-3 Standards

SOLO BARS

A solenoid valve, operated by electromagnetism, regulates the flow of various substances. Its primary task is to control the flow or distribution of fluids or gases as needed. Comprising a plunger and a core tube, it's energized by a coil, allowing for precise flow adjustments without overheating.

FORMS

- Shape: Round
- Diameter: 5 mm (3/16") – 55 mm (2 3/16")]
- Tolerance: ASTM A484 and ISO 286
- Length: 2.0 m (6.5') – 7.8 m (25.5')
- Surface: 0.4 μ
- Magnetic Annealed

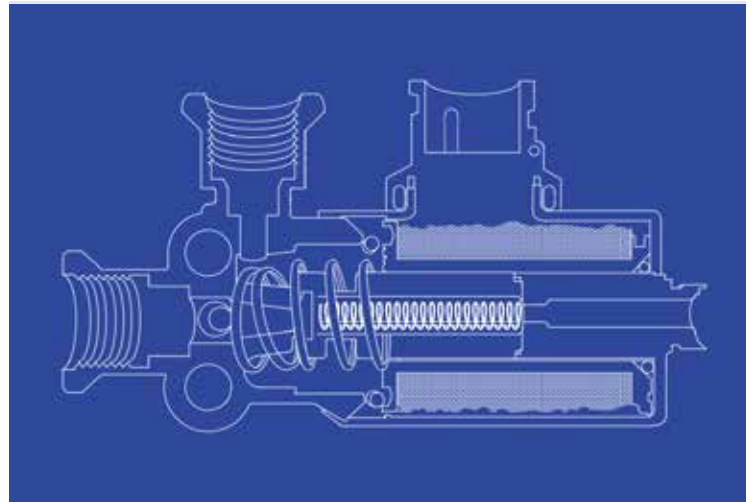

NORM

VENUS	ASTM A838	EN 10088-3	DIN
SOLO 12	Alloy1 , Grade 2	1.4105	X6CrMiS17
SOLO 21	Alloy2 , Grade 1	1.4105	X6CrMiS17
SOLO 34	-	1.4106	X6CrMiS17

PHYSICAL PROPERTIES

Our typical values for this grade's physical properties are as follows.

Density	Specific Heat (20C)	Conductivity (20C)	Electrical Resistivity	Thermal Expansion	Curie Temperature	Modulus Elasticity
7.62 g/cm ³	460 J/Kg.K	23 W/m/K	600 μΩmm	11.9x10 ⁻ /K	660 °C	220 kN/mm ²
0.276 lb/in ³	0.109 Btu/lb/F	13.28 Btu/ft/hr/F	360 ohms-cir mil/014	6.6x10 /F	1240°F	31.9 x 10 ⁻⁶ psi

* Mean Coefficient of Linear Thermal Expansion from 20 °C to 500 °C.

MAGNETIC PROPERTIES

Grade	Saturation (Bs)	Relative Permeability (μ)	Coercive Force* (Hc)	Residual Induction (Br)
SOLO 12	1.6 T min	400 min	480 A/m max	0.60 T min
SOLO 21	1.6 T min	1200 min	206 A/m max	11 T min
SOLO 34	1.6 T min	1400 min	300 A/m max	0.50 T min

* Measured at Field Strength 60000 A/m

INDUSTRY SEGMENT

Venus Bright Bars are used in various industrial segments for highly critical applications.



Energy

- Power Generation



Automotive

- Light Duty Vehicles
- Medium & Heavy Duty Vehicles



Food & Agriculture

- Equipment
- Feeding & Watering Systems



Medical

- Orthopedics
- Cardiology
- Dental
- Surgical Tools



Oil & Gas

- Oil & Gas Offshore
- Oil & Gas Onshore
- Power Generation
- Manufactured Parts



Defense

- Rotorcraft
- Marine
- Weaponry
- Armored Vehicles



Aerospace

- Engine
- Structural
- Fasteners



Nuclear

- Storage Tanks
- Reactor Vessels
- Heat Exchanger



INNOVATIVE & HIGH-VALUE PRODUCTS

AISI	Wr. No.	APPLICATIONS
303	1,4305	Shafts, valves, valve stems and fittings, machine components, components for fuel injection systems, electrical switch gear components, nuts and bolts.
304/304L	1,4301/1.4307	Food processing, dairy, various industrial components
310	1.4845	High temperature applications
316/316L	1,4401/1.4404	High corrosion resistance applications. Oil field parts
316Ti	1,4571	High temperature applications, brewery equipments
321	1,4541	Aeronautical application, automotive exhaust manifolds, expansion joints, high temperature chemical processing equipments
630	1,4542	Oil field valve parts, fasteners, pump shafts, nuclear reactor components, chemical process equipments, pharmaceutical equipments
409Cb	1,4512	Muffler hanger, automotive components
410	1,4006	Valves, fasteners, shaft, pump parts, petrochemical equipments, machine parts, cutlery, true tuff
416	1,4005	Pump Shafts, Valve Stems, Gun Barrel

AISI	Wr. No.	APPLICATIONS
420	1,4021	Cutlery, surgical instruments, shafts, X-mas tree equipments, controlled valve
420	1,4028	Shafts, machined components, controlled valve
430F	1,4104	Pump shafts, piston shafts
430LNb	1.4511	Exhaust system, sensor parts
430F	1,4105	Solenoid valves
431	1,4057	Aircraft components, pump shafts, valve stems, threaded bushings
-	1.4122	Automated industry, pump shafts, cutting tools, food & beverage industry, building industry
415	1.4418	Automotive fuel pump parts
S66286/A286	-	High-performance springs, motor vehicle turbochargers, fasteners, High-performance springs
N07718/718	-	Stationary gas turbines, rocket drives, space craft, automotive turbochargers, high-strength screws, springs, mounting elements, as well as in heat-resistant tools for forges, extruders, and separating shearers
N06625/625	-	Aerospace, oil and gas, marine engineering, springs and fasteners

PACKAGING

AREA OF APPLICATIONS

- In Bundles of 500-1000 kgs. (1000-2000 Lbs.) covered with HDPE.
- In wooden boxes (complying ISPM - 15 standards) 500-1000 kgs. (1000-2000 Lbs.) with lifting belts.
- Wrapped with rust preventive paper for selected grades.
- Bars are collared to protect finish.
- Customized Packaging available.
- Bars are also offered in Fiber tube packing.



Rings are used for better protection



Color Coded



Bars wrapped in moisture absorbing paper



Packed in Wooden Boxes



Straps provided for easy lifting with fork lift



Boxes stacked & labels provided for easy identification



Fiber Tube Packaging

WE DELIVER **GREATER VALUE**

Venus provides a number of packaging options to best suit the logistics, storage & statutory requirement.



QUALITY

Venus has top class quality lab certified by NABL with latest equipments to provide its customer with high quality products.

Mechanical Testing Facilities

1. UTM Machine (400KN, Servo control) – Tensile testing
2. Impact Testing Machine
3. Brinell Hardness Testing Machine
4. Rockwell Hardness testing Machine
5. Profile Projector

Chemical Testing Facilities

1. ARL 3460 Optical Emission Spectrometer – 27 channel
2. PMI gun

Metallography Testing Facilities

1. Carl Zeiss Metallurgical Microscope (50x -1000x)
2. (Inclusion Rating, Grain size, Microstructure, Delta ferrite Analysis)

Corrosion Testing

1. IGC practice A,B,C & E
2. Salt spray testing Machine

Others

1. Surface Roughness Testing
2. Ferrite content by ferrite scope
3. Gauss meter (To check residual magnetism in the material)
4. Hysteresis Loop testing (Magnetic Permeability of the material)

Non Destructive Testing

1. Ultrasonic Testing m/c

- a) Phase Array Volumetric checking upto 0.7 mm FBH, Size range – 10 mm upto 65mm)
- b) Manual Volumetric checking upto 1.5 mm FBH, Size range – 65 mm & above

2. Eddy Current Testing

a) Defactomat

- Transverse flaws and Pin Holes.
- Depth up to 1% of Diameter.
- Size Range from 5mm upto 65mm.

b) Circograph (Eddy current with Rotating Head)

- Detection of surface flaws, in particular Longitudinal Flaws.
- Depth up to 1% of Diameter.
- Size Range from 5mm upto 65mm.

3. Anti-Grade-mix Sorting Machine

- Through this machine we can ensure there 0% grade mix-up.
- MPI – Wet flurocesnt
- LPT/DP

Round Bar Grade

ASTM	EN	BS	AFNOR	JIS	Wr.No.
410L	X2CrNi12	-	-	SUS410L	1.4003
416	X12CrS13	416S21	Z11CF13	SUS416	1.4005
410	X12Cr13	410S21	Z10C13	SUS410	1.4006
420	X20CR13	420S37	Z20C13	SUS 420J1	1.4021
420B	X30CR13	-	-	SUS 420J2	1.4028
420C	X46CR13	-	-	SUS 420J2	1.4034
431	X17CrNi16-2	431S29	-	SUS431	1.4057
440B	X90CrMoV18	-	-	SUS440B	1.4112
415M	-	-	-	-	1.4418
440B	X90CrMoV18	-	-	SUS440B	1.4112
440C	X105CrMo17	-	-	SUS 440C	1.4125
441	X2CrTiNb18	-	-	-	1.4509
430LNB	-	-	-	-	1.4511
430LTINB	-	-	-	-	1.4509
409	X2CrTi12	409S	Z3CT12	SUS409L	1.4512
430	X6Cr17	430S17	Z8C17	SUS430	1.4016
430F	X14CrMoS17	-	Z 10 CF 17	-	1.4104
430FR	-	-	-	-	1.4105
434	X6CrMo17-1	-	-	SUS434	1.4113
321S	-	-	-	-	1.4162
304	X5CrNi18-10	304S15	Z5CN18-09	SUS304	1.4301
305	X4CrNi18-12	305S19	Z1CN18-12	SUS305J1	1.4303
303	X8CrNiS18-9	303S31	Z8CNF18-09	SUS303	1.4305
304S	-	-	-	-	1.4306
304L	X2CrNi19-11	304S11	Z2CN18-10	SUS304L	1.4306
304LN	X2CrNiN18-10	304S61	Z3CN18-10Az	SUS304LN	1.4311
201	X12CrMnNiN17-7-5	-	Z12CMN17-07Az	SUS201	1.4372

Round Bar Grade

ASTM	EN	BS	AFNOR	JIS	Wr.No.
202	X12CrMnNiN18-9-5	-	-	SUS202	1.4373
316	X5CrNiMo17-12-2	316S31	Z6CND17-11	SUS316	1.4401
316L	X2CrNiMo17-12-2	316S11	Z2CND17-12	SUS316L	1.4404
317L	-	-	-	-	1.4438
321	X6CrNiTi18-10	321S31	Z6CNT18-10	SUS321	1.4541
302	X9CrNi18-9	-	-	SUS302	1.4325
316Ti	X6CrNiMoTi17-12-2	320S31	Z6CNDT17-12	SUS316Ti	1.4571
309	X15CrNiSi20-12	-	-	SUS309	1.4828
314	X15CrNiSi25-21	310 S 24	Z 12 CNS 25.20	SUS314	1.4841
310	X8CrNi25-21	310S16	Z8CN25-20	SUS310S	1.4845
321H	X7CrNiTi18-10	-	-	SUS321H	1.4878
304H	X7CrNi18-9	-	-	-	1.4948
347	X6CrNiNb18-10	347S31	Z6CNNb18-10	SUS347	1.4550
2205	X2CrNiMoN 22.5.3	318S13	Z3 CrNi 22.05 AZ	SUS 329J3L	1.4462
2304	X2 Cr Ni 23.4	-	Z3 CN 23.04 Az	-	1.4362
329	X3CrNiMoN27-5-2	-	Z5CND27-05Az	SUS329J1	1.4460
630	X5CrNiCuNb16-4	-	-	SUS 630	1.4542
427	-	-	-	-	-
C465	-	-	-	-	-
209	X2CrNiMnMoNNb	-	-	XM-19	1.4455
218	-	-	-	-	-
A286	-	-	-	-	1.498
718	-	-	-	-	2.4668
625	-	-	-	-	-
925	-	-	-	-	-
825	-	-	-	-	-
L605	-	-	-	-	2.4999



CORPORATE OFFICE (INDIA)

Venus Wire Industries Pvt. Ltd.
Mehta Mahal, Opera House,
Mumbai 400004, India.
Phone : +91-22-48871000
venuswires@venuswires.com

USA

Fortis Metals NA Inc.
info@fortismetals.us

GERMANY

Venus Edelstahl GmbH
Eilper Str. 71-75 58091,
Hagen, Nordrhein-Westfalen
Phone : +49 (0) 2331 9760472
Fax: +49 (0) 23 31 7393811
info@venus-edelstahl.de